

OPERATING INSTRUCTIONS FOR FASTENER DRIVING TOOLS OPERATED BY COMPRESSED AIR



10L HAND MIXING PAINT TANK
8318H



10L AUTOMATIC MIXING PAINT TANK
8318A



30L HAND MIXING PAINT TANK
8311H



30L AUTOMATIC MIXING PAINT TANK
8311A



40L HAND MIXING PAINT TANK
8317H



40L AUTOMATIC MIXING PAINT TANK
8317A

2016



IMPORTANT:

Read all safety rules and operating Instructions carefully before first use it. Keep this Manual for future reference.



Residual risks

Even when the tool is used as prescribed it is not possible to eliminate all residual risk factors. The following hazards may arise in connection with the tool's construction and design:

- Damage to lungs if an effective dust mask is not worn.



- Damage to hearing if effective hearing protection is not worn.



- Health defects resulting from vibration emission if the power tool is being used over longer period of time or not adequately managed and properly maintained.

- Wear eye protection.



Description:

Sturdy construction and compact design makes this products the ideal choice for both amateur and professional. Pressure spray gun equipped with pressure gauge and fluid pressure regulator for accurate settings. Twin set of hoses permits easy movement and operation of spray gun. Excellent for large areas such as buses, trucks and vans.

Technical Data:

| Item No. | 8318H | 8318A | RP8311H | RP8311A |
|-------------------|---------------|---------------|---------------|---------------|
| Working Pressure: | 1.4-2.1Bar | 1.4-2.1Bar | 1.4-2.1Bar | 1.4-2.1Bar |
| Capacity: | 10L | 10L | 30L | 30L |
| Paint output: | 1/4" | 1/4" | 1/4" | 1/4" |
| Dimension: | 259*246*465mm | 259*245*580mm | 417*324*730mm | 400*324*630mm |
| Inner paint Dia.: | 234mm | 234mm | 310mm | 310mm |
| Inner height: | 208mm | 208mm | 380mm | 380mm |

| Item No. | 8317H | 8317A |
|-------------------|---------------|---------------|
| Working Pressure: | 1.4-2.1Bar | 1.4-2.1Bar |
| Capacity: | 40L | 40L |
| Paint output: | 1/4" | 1/4" |
| Dimension: | 417*390*915mm | 417*390*810mm |
| Inner paint Dia.: | 370mm | 370mm |
| Inner height: | 384mm | 384mm |

Safety Guidelines:

This manual contains information that is important for you to know and understand. This information relates to protecting your safety and preventing equipment problems. Improper operation or maintenance of this product could result in injury or property damage. Read and understand all warnings and operating instructions before use. Save these instructions.

Warning! Over pressurization of attachments can result in explosion.

1. Attachments with a pressure rating lower than the adjusted pressure in the tank can explode, resulting in serious injury or property damage. Always make sure that equipment connected to tank or hose outlet has a higher pressure rating than the regulated air pressure in the tank.

Warning! Risk of tank explosion. Explosive failure of the tank, its components or attachments can result in serious injury to self and others or property damage.

1. Modifications to the tank's design or construction could weaken it. Assemble tank components in accordance with the service instructions. Do not drill into tank, or weld attachments, or alter its design in any manner.
2. Substitution of unauthorized non-standard components could weaken tank or cause component failure. Use only those components furnished with the tank. Assembled in accordance with instructions in the service literature.
3. Damage to the tank or its components could weaken the tank. Never attempt to repair a damaged tank. Replace it with a new one.
4. Improper cleaning or maintenance could block air passages to the safety valve, gauge or outlet, allowing pressure to rise to dangerous levels, and preventing the lowering of tank pressure. Following each use, clean and dry tank and lid in accordance with maintenance instructions. Ensure ports to safety valve, gauge and outlet are free of hardened paint or other materials which could prevent free movement of air.
5. Tampering with the safety valve could allow tank pressure to rise to dangerous levels. Never attempt to adjust safety valve to change its pressure setting, or defeat its function in any way. Operate the valve before each use to assure that it functions properly.
6. Removal of the lid while the tank is under pressure could result in the lid being propelled violently from the tank. Before releasing clamp force to remove the lid, shut off the supply of tank inlet air and turn the regulator knob counter-clockwise to relieve air pressure. Check by pulling the safety valve ring.
7. Use of reactive chemicals could attack the lid gasket and safety valve seal, allowing tank pressure to rise to dangerous levels. Halogenated hydrocarbon solvents, such as trichloroethane and ethylene chloride can chemically react with aluminum. If this reaction occurs within an enclosed structure such as this tank, it may cause explosion. Do not use reactive chemicals in your tank such as acids, caustic solutions, or halogenated hydrocarbon solvents.
8. Over tightening clamps, causing them to weaken and fail could result in the lid being propelled violently from the tank. If the lid gasket leaks, relieve the tank pressure and clean or replace the gasket.

Assembly

1. Connect the regulator assembly to the swivel adapter on the tank lid. Check bottom of regulator for location of tank connection.
2. Insert the lift handle into the threaded hole in the center of the tank lid. Tighten hex nut.
3. Connect the air supply hose to an air inlet fitting on the tank regulator (right or left side optional.)
4. Attach the atomization air hose to an air outlet fitting which is directly opposite air inlet fitting.

5. Connect material hose to the fluid outlet adapter located on the tank lid.

Using an air pressure regulator on paint tank

The pressure regulator on the paint tank regulates the amount of pressure applied to the paint in the paint tank. This controls the pressure of the paint being delivered to the spray gun.

Recommended paint tank pressures.

Internal mix guns: Use higher tank pressures up to the full amount of air pressure being delivered to the spray gun.

External mix guns: Use lower tank pressures. Always start with the pressure in the tank at zero and increase pressure in the tank gradually until the proper spray pattern is obtained.

Important: Before turning on air pressure, completely loosen the regulator T-handle adjusting screw to shut off the air pressure. Turn on the air, then, adjust the regulator to the required pressure (approximately 0.83bar for external –mix guns.) Do not use over 3.45bar pressure in the paint tank. Part of the air from the compressor or airline bypasses pressure regulator through the T-fitting and is delivered to spray gun operation. Therefore an additional pressure regulator will be required between the T-fitting and the spray gun for accurate pressure at the spray gun.

Operation:

1. Before filling the tank with material, thoroughly mix and strain the paint to remove skins or undissolved particles with might otherwise block the flow of material through the hose and gun. A one gallon of paint can be set inside the tank instead of pouring the paint into the tank.
2. Place lid assembly on tank and hand tighten tank lid clamp screws.
3. Shut off the paint tank regulator by turning T-handle counter-clockwise. Adjust the compressor regulator to obtain the desired air pressure on the spray gun.
4. Now adjust the regulator on the paint tank to obtain the desired air pressure for the material. The higher above the paint tank you are spraying, the more pressure you will need on the material. Normal operating pressure on the paint tank is 1.7 to 2.0bar. Should you wish to reduce pressure, simply rotate the T-handle adjusting screw counter clockwise until the desired pressure setting is obtained. There is no need to trigger the gun in order to bleed off excess paint pressure.

Warning: Do not use over 3.0bar air pressure in your tank.

Cleaning:

Warning: Always shut off air pressure at source and bleed off all pressure in the paint tank by gently pulling safety valve ring before loosening thumb screw and clamps to remove lid.

It is very important that the tank, material hose and spray gun be cleaned as soon as the spray job is finished. Turn off the main air supply to the tank. Remove all pressure from the tank by pulling the ring on the safety valve until the pressure bleeds down. Turn the T-handle adjusting screw on the regulator counter-clockwise until no spring tension is felt.

Loosen thumb screws, tip clamps back and tip tank lid down to one side. Loosen spray gun air cap retaining ring about three turns then turn on the air supply. Cup cloth over air cap on the gun and pull trigger. This will force the material back through the hose. into the tank. Empty and clean tank and parts which come in contact with the material. Use a suitable solvent. Pour solvent into the tank. Replace lid and tighten the thumb screws and clamps and spray until clean solvent appears.

Exploding view & Parts list for RP8318H

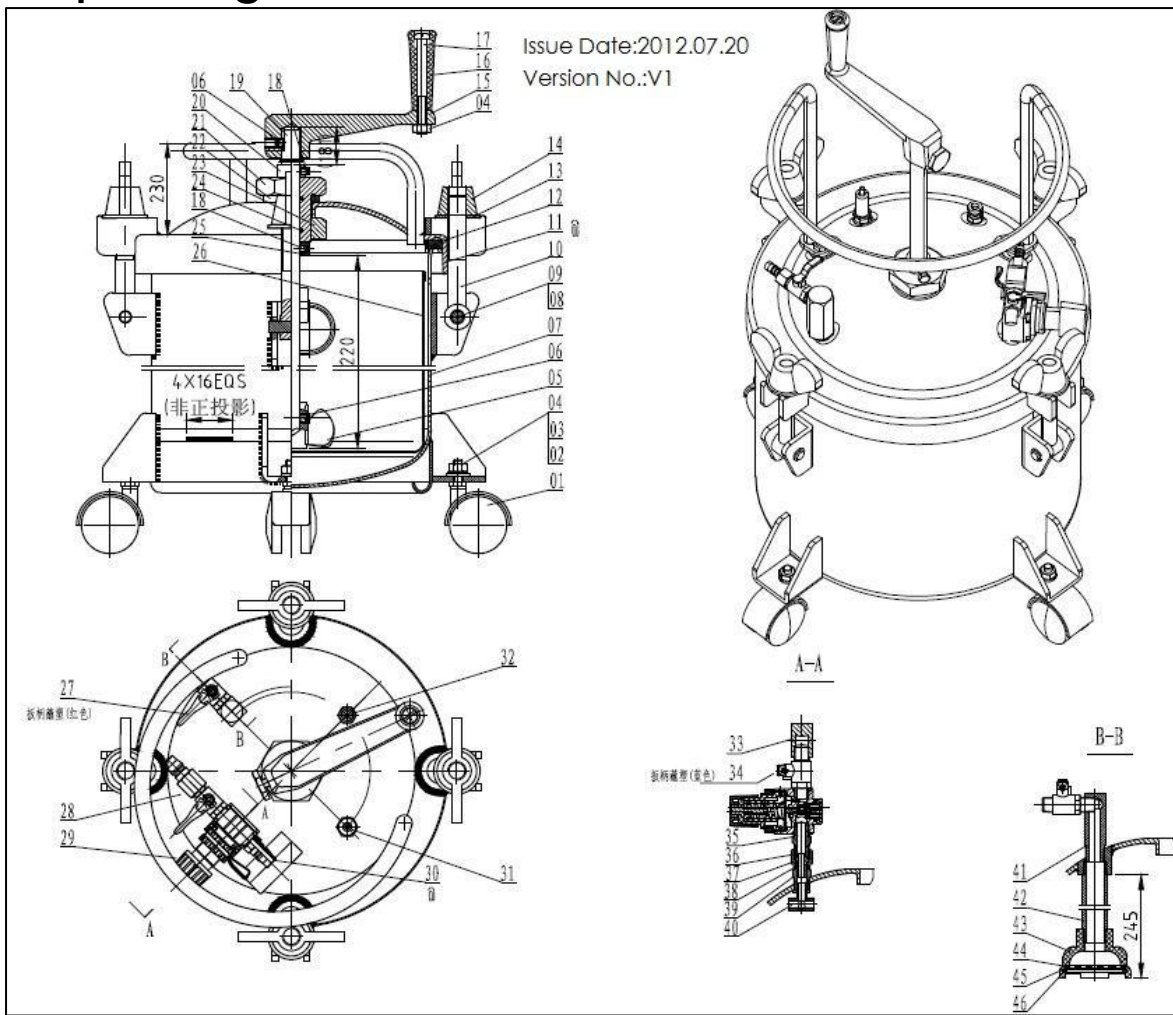

| No. | Description | Qty. | No. | Description | Qty. | No. | Description | Qty. |
|-----|--------------------------|------|-----|--------------------------------|------|-----|-----------------------|------|
| 1 | All around wheel | 4 | 17 | Bolt | 1 | 33 | Air Inlet seat | 1 |
| 2 | Flat Washer | 4 | 18 | Hex bolt | 2 | 34 | Gas valve | 1 |
| 3 | Spring washer | 4 | 19 | Rocker | 1 | 35 | Pressure tapping | 1 |
| 4 | Hex Nut | 5 | 20 | locating ring | 1 | 36 | Union nut | 1 |
| 5 | Blade | 1 | 21 | Locating seat | 1 | 37 | Inlet paint joint | 1 |
| 6 | Bolt | 2 | 22 | Sealing washer | 1 | 38 | Thin Nut | 1 |
| 7 | Tank assemblage | 1 | 23 | Nut | 1 | 39 | Air inlet Plug | 1 |
| 8 | Cross pin | 4 | 24 | O-ring | 2 | 40 | Air converter | 1 |
| 9 | Snap retainer | 8 | 25 | Inside locating ring | 1 | 41 | Paint joint | 1 |
| 10 | Lock screw | 4 | 26 | Tank assemblage | 1 | 42 | Paint absorption tube | 1 |
| 11 | Reservoir cap assemblage | 1 | 27 | Gas valve | 2 | 43 | Filtration stand | 1 |
| 12 | Pot lid seal ring | 1 | 28 | Internal thread male connector | 1 | 44 | Filter gasket | 1 |
| 13 | Washer | 4 | 29 | Voltage regulator | 1 | 45 | Filter screen | 1 |
| 14 | Butterfly nut | 4 | 30 | Male thread male connector | 1 | 46 | Filter Circlip | 1 |
| 15 | Connect seat | 1 | 31 | Relief valve components | 1 | | | |
| 16 | Trigger piece | 1 | 32 | Release valve | 1 | | | |

Exploding view & Parts list for RP8318A

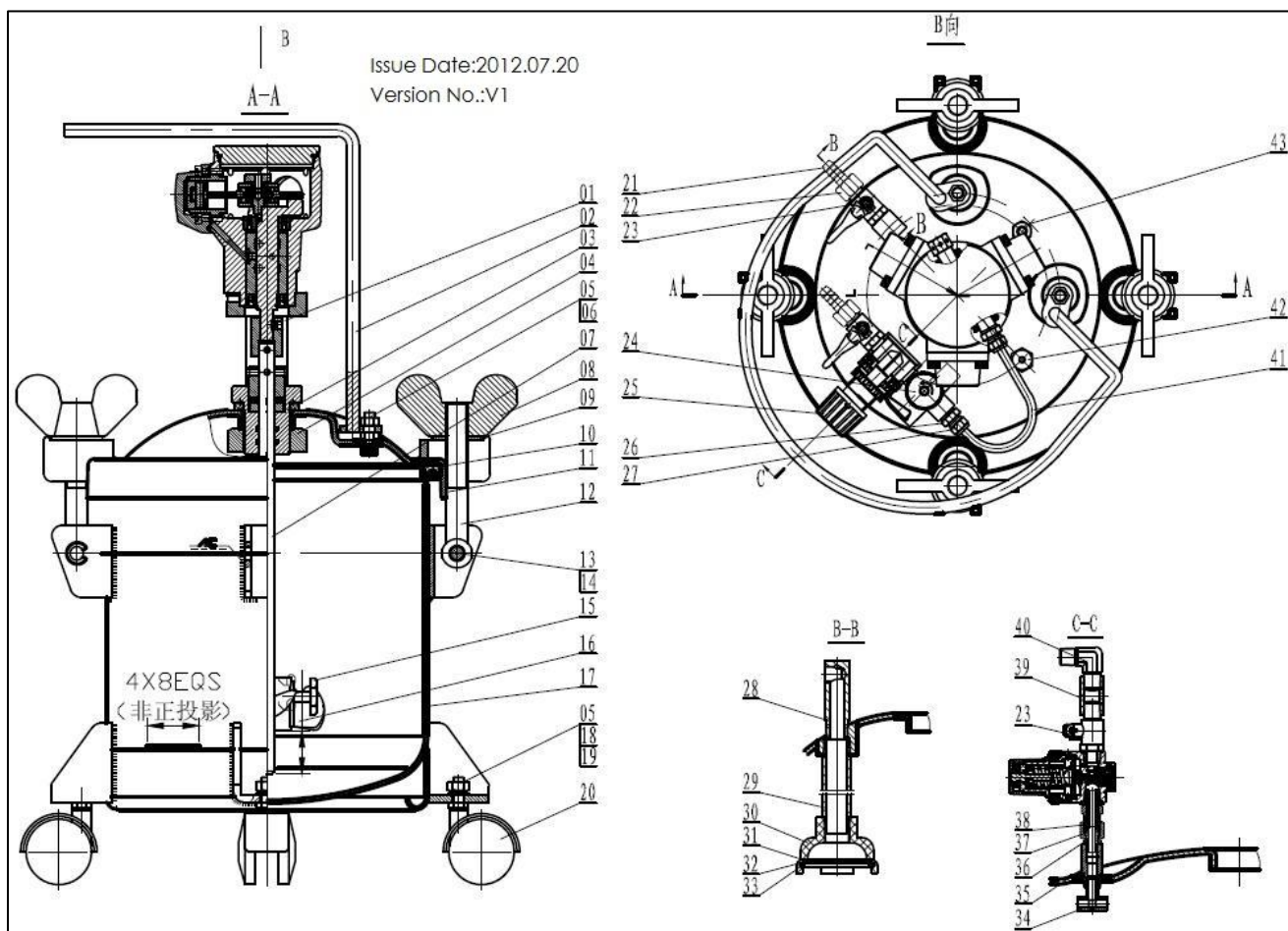

| No. | Description | Qty. | No. | Description | Qty. | No. | Description | Qty. |
|-----|--------------------------|------|-----|-----------------------|------|-----|-------------------------|------|
| 1 | Automatic pump assembly | 1 | 16 | Blade | 1 | 31 | Filtration stand | 1 |
| 2 | Handle | 1 | 17 | Tank assemblage | 1 | 32 | Filter screen | 1 |
| 3 | Sealing washer | 1 | 18 | Spring washer | 4 | 33 | Filter Circlip | 1 |
| 4 | Nut | 1 | 19 | Flat Washer | 4 | 34 | Air converter | 1 |
| 5 | Hex Nut | 8 | 20 | All around wheel | 4 | 35 | Air inlet plug | 1 |
| 6 | Hex Bolt | 2 | 21 | Connector | 2 | 36 | Thin nut | 1 |
| 7 | Rocker | 1 | 22 | Union nut | 2 | 37 | Inlet paint joint | 1 |
| 8 | Butterfly nut | 4 | 23 | Gas valve | 3 | 38 | Union nut | 1 |
| 9 | Washer | 4 | 24 | Head Valve assembly | 1 | 39 | Air inlet seat | 1 |
| 10 | Sealing washer | 1 | 25 | Pressure regulator | 1 | 40 | Pipe joint | 1 |
| 11 | Reservoir cap assemblage | 1 | 26 | Air inlet plug | 2 | 41 | Leather hose | 1 |
| 12 | Lock bolt | 4 | 27 | Hose nut | 2 | 42 | Relief valve components | 1 |
| 13 | Snap retainer | 8 | 28 | Paint joint | 1 | 43 | Release valve | 1 |
| 14 | Cross pin | 4 | 29 | Paint absorption tube | 1 | | | |
| 15 | Hex bolt | 1 | 30 | Filter gasket | 1 | | | |

Exploding view & Parts list for RP8311H

2014.06.06

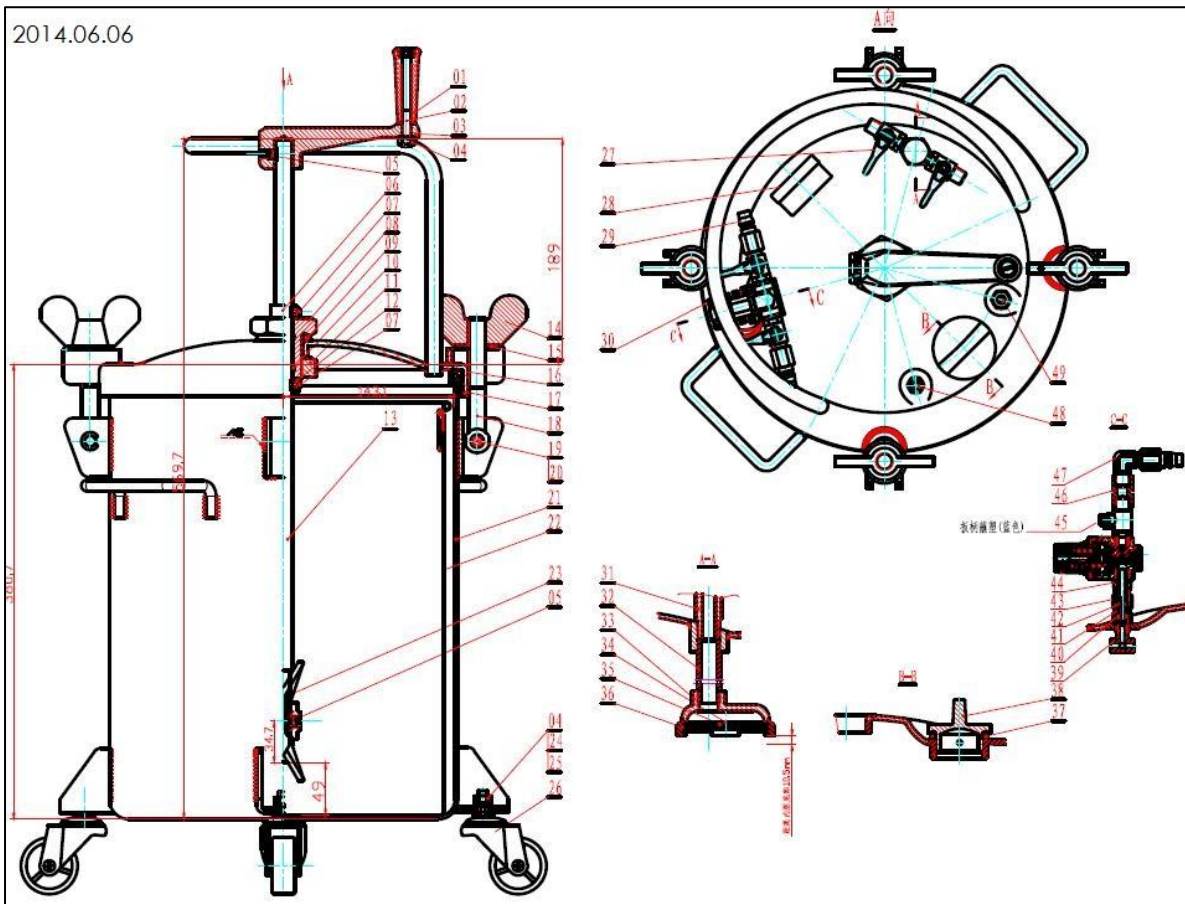

| No. | Description | Qty. | No. | Description | Qty. | No. | Description | Qty. |
|-----|--------------------------|------|-----|--------------------------------|------|-----|-------------------------|------|
| 1 | Trigger piece | 1 | 18 | Lock screw | 4 | 35 | Filter screen | 1 |
| 2 | Bolt | 1 | 19 | Cross pin | 4 | 36 | Filter Circlip | 1 |
| 3 | Connect seat | 1 | 20 | Snap retainer | 8 | 37 | Sealing washer | 1 |
| 4 | Hex Nut | 5 | 21 | Tank assemblage | 1 | 38 | End cap | 1 |
| 5 | Bolt | 2 | 22 | Inside tank assemblage | 1 | 39 | Air converter | 1 |
| 6 | Locating ring | 1 | 23 | Blade | 1 | 40 | Air inlet plug | 1 |
| 7 | Bolt | 2 | 24 | Spring washer | 4 | 41 | Thin nut | 1 |
| 8 | Locating seat | 1 | 25 | Flat washer | 4 | 42 | Inlet paint joint | 1 |
| 9 | Sealing washer | 1 | 26 | All around wheel | 4 | 43 | Union Nut | 1 |
| 10 | O-ring | 2 | 27 | Gas valve | 4 | 44 | Pressure tapping | 1 |
| 11 | Nut | 1 | 28 | Pressure gauge | 1 | 45 | Gas valve | 1 |
| 12 | Inside locating ring | 1 | 29 | Internal thread male connector | 3 | 46 | Air inlet seat | 1 |
| 13 | Rocker | 1 | 30 | Voltage regulator | 1 | 47 | Pipe joint | 1 |
| 14 | Butterfly Nut | 4 | 31 | Paint joint | 1 | 48 | Release valve | 1 |
| 15 | Washer | 4 | 32 | Paint absorption tube | 1 | 49 | Relief valve components | 1 |
| 16 | Sealing washer | 1 | 33 | Filtration Stand | 1 | | | |
| 17 | Reservoir cap assemblage | 1 | 34 | Filter gasket | 1 | | | |

Exploding view & Parts list for RP8311A

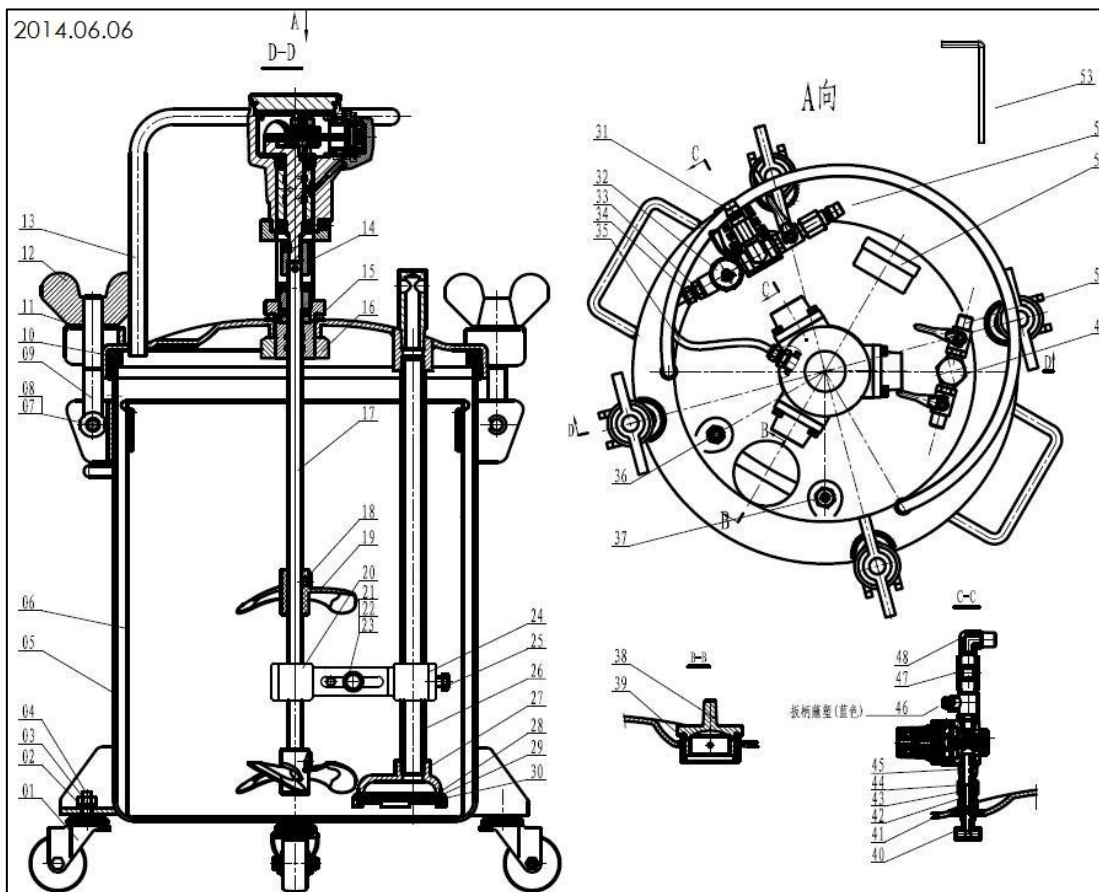

| No. | Description | Qty. | No. | Description | Qty. | No. | Description | Qty. |
|-----|--------------------------|------|-----|-----------------------------|------|-----|--------------------------------|------|
| 1 | All around wheel | 4 | 19 | Blade | 2 | 37 | Relief valve components | 1 |
| 2 | Flat washer | 4 | 20 | Rocker Stand | 1 | 38 | End cap | 1 |
| 3 | Spring washer | 4 | 21 | Flat washer | 1 | 39 | Sealing washer | 1 |
| 4 | Hex nut | 4 | 22 | Spring washer | 1 | 40 | Air converter | 1 |
| 5 | Tank assemblage | 1 | 23 | Hex bolt | 1 | 41 | Air inlet plug | 1 |
| 6 | Inside Tank assemblage | 1 | 24 | Paint absorption tube stand | 1 | 42 | Thin nut | 1 |
| 7 | Cross pin | 4 | 25 | Hex bolt | 1 | 43 | Inlet paint joint | 1 |
| 8 | Snap retainer | 8 | 26 | Paint absorption tube | 1 | 44 | Union nut | 1 |
| 9 | Lock screw | 4 | 27 | Filtration stand | 1 | 45 | Pressure tapping | 1 |
| 10 | Sealing washer | 1 | 28 | Filter gasket | 1 | 46 | Gas valve | 1 |
| 11 | Washer | 4 | 29 | Filter | 1 | 47 | Air inlet seat | 1 |
| 12 | Butterfly nut | 4 | 30 | Filter circlip | 1 | 48 | Air connector | 1 |
| 13 | Reservoir cap assemblage | 1 | 31 | Pressure regulator | 1 | 49 | Paint joint | 1 |
| 14 | Automatic pump assembly | 1 | 32 | Head valve assembly | 1 | 50 | Gas valve | 3 |
| 15 | Sealing washer | 1 | 33 | Air inlet plug | 2 | 51 | Pressure gauge | 1 |
| 16 | Nut | 1 | 34 | Hose nut | 2 | 52 | Internal thread male connector | 2 |
| 17 | Rocker | 1 | 35 | Hose | 1 | 53 | Wrench | 1 |
| 18 | Bolt | 2 | 36 | Release valve | 1 | | | |

Exploding view & Parts list for RP8317H

Issue Date:2012.07.20
Version No.:V1

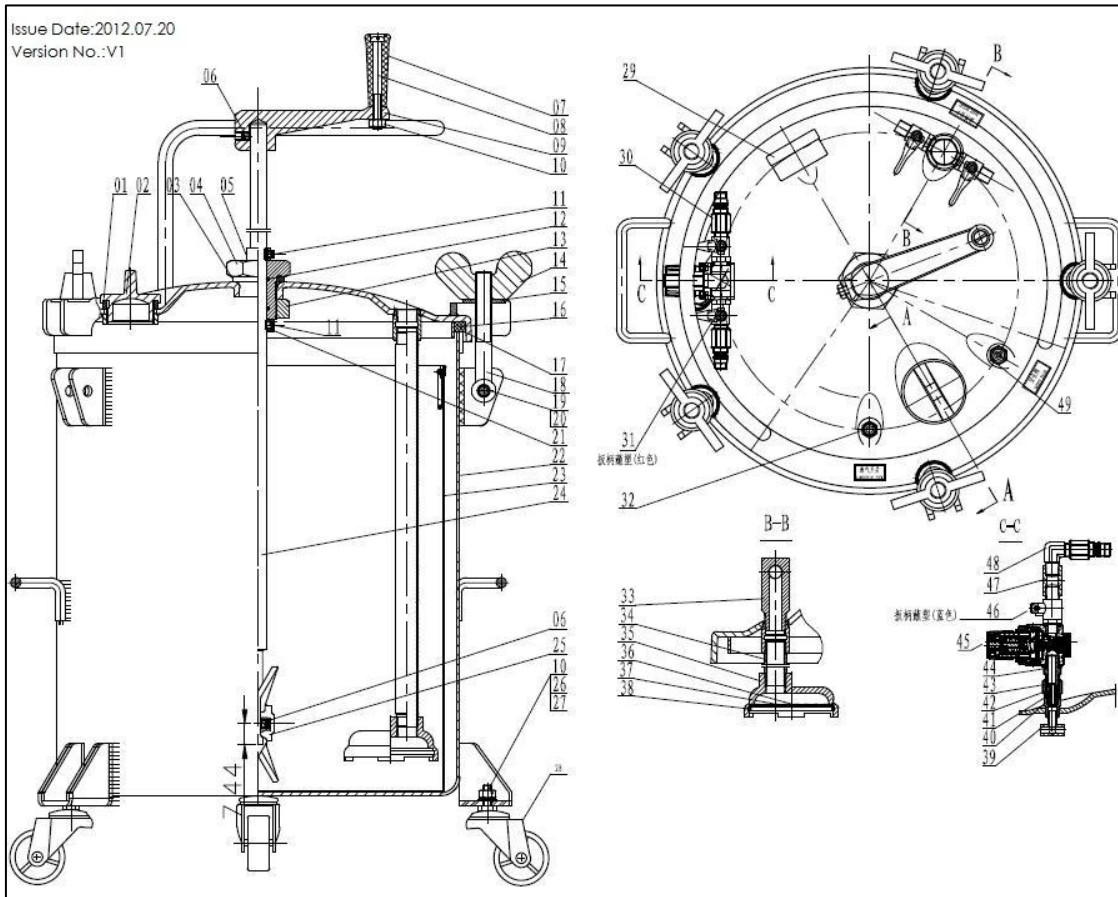

| No. | Description | Qty. | No. | Description | Qty. | No. | Description | Qty. |
|-----|--------------------------|------|-----|--------------------------------|------|-----|-------------------------|------|
| 1 | Sealing washer | 1 | 18 | Lock screw | 5 | 35 | Filtration stand | 1 |
| 2 | End cap | 1 | 19 | Cross pin | 5 | 36 | Filter gasket | 1 |
| 3 | Sealing washer | 1 | 20 | Snap retainer | 10 | 37 | Filter screen | 1 |
| 4 | Locating seat | 1 | 21 | Inside locating ring | 1 | 38 | Filter circlip | 1 |
| 5 | Locating ring | 1 | 22 | Tank assemblage | 1 | 39 | Air converter | 1 |
| 6 | Allen screws | 2 | 23 | Inside tank assemblage | 1 | 40 | Air inlet Plug | 1 |
| 7 | Trigger piece | 1 | 24 | Rocker | 1 | 41 | Thin nut | 1 |
| 8 | Bolt | 1 | 25 | Blade | 1 | 42 | Inlet paint joint | 1 |
| 9 | Connect seat | 1 | 26 | Flat washer | 5 | 43 | Union nut | 1 |
| 10 | Hex nut | 6 | 27 | Spring washer | 5 | 44 | Pressure tapping | 1 |
| 11 | Allen screw | 3 | 28 | All around wheel | 5 | 45 | Voltage regulator | 1 |
| 12 | O-ring | 2 | 29 | Pressure gauge | 2 | 46 | Gas valve | 1 |
| 13 | Nut | 1 | 30 | Internal thread male connector | 3 | 47 | Air inlet seat | 1 |
| 14 | Butterfly nut | 5 | 31 | Gas valve | 4 | 48 | Pipe joint | 1 |
| 15 | Washer | 5 | 32 | Release valve | 1 | 49 | Relief valve components | 1 |
| 16 | Sealing washer | 1 | 33 | paint joint | 1 | | | |
| 17 | Reservoir-cap assemblage | 1 | 34 | Paint absorption tube | 1 | | | |

Exploding view & Parts list for RP8317A

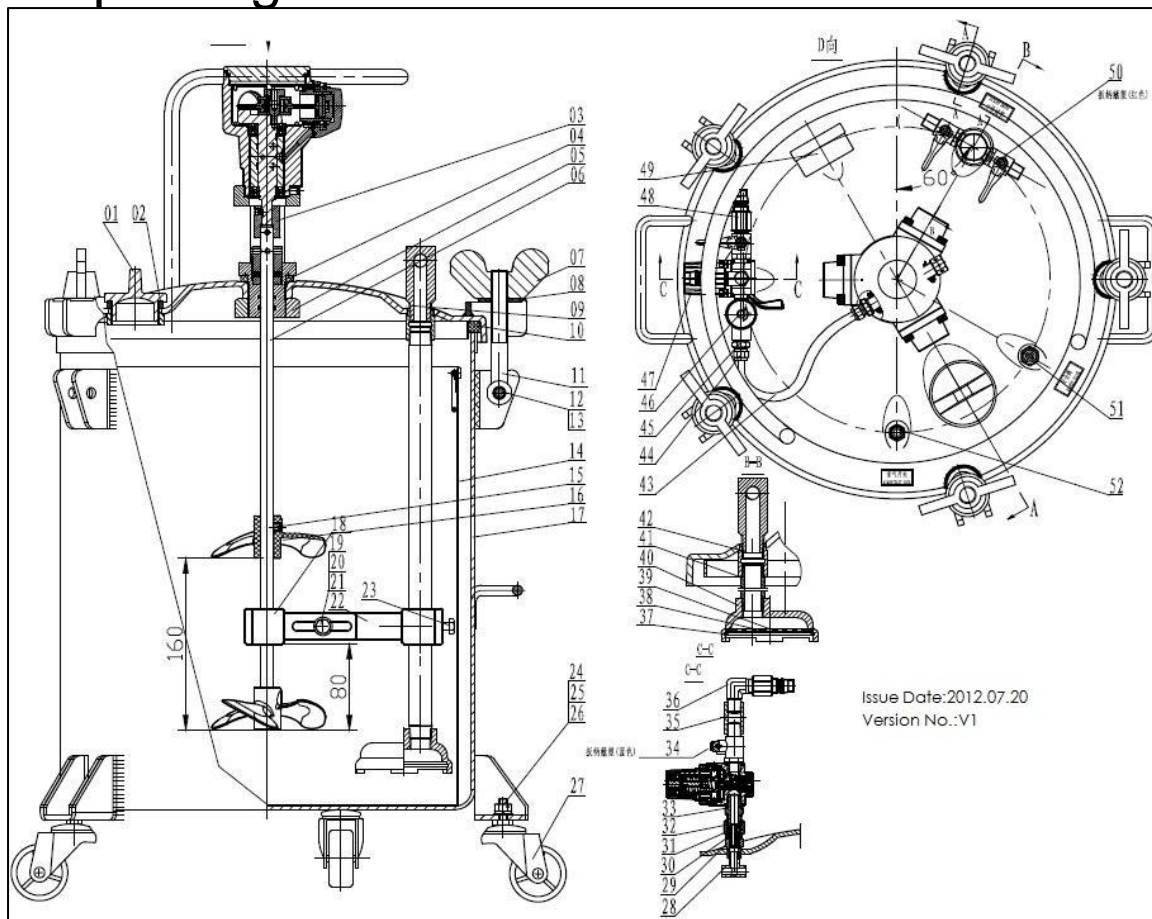

| No. | Description | Qty. | No. | Description | Qty. | No. | Description | Qty. |
|-----|--------------------------|------|-----|-----------------------------|------|-----|--------------------------------|------|
| 1 | End cap | 1 | 19 | Flat washer | 1 | 37 | Filter circlip | 1 |
| 2 | Sealing washer | 1 | 20 | Spring washer | 1 | 38 | Filter gasket | 1 |
| 3 | Automatic pump assembly | 1 | 21 | Hex bolt | 1 | 39 | Filter | 1 |
| 4 | Sealing washer | 1 | 22 | Paint absorption tube stand | 1 | 40 | Filtration Stand | 1 |
| 5 | Nut | 1 | 23 | Hex bolt | 1 | 41 | Paint absorption tube | 1 |
| 6 | Rocker | 1 | 24 | Flat washer | 5 | 42 | Paint joint | 1 |
| 7 | Butterfly nut | 5 | 25 | Spring washer | 5 | 43 | Leather hose | 1 |
| 8 | Washer | 5 | 26 | Hex nut | 5 | 44 | Air inlet plug | 2 |
| 9 | Reservoir cap assemblage | 1 | 27 | All around wheel | 5 | 45 | Hose Nut | 2 |
| 10 | Sealing washer | 1 | 28 | Air converter | 2 | 46 | Head valve assembly | 1 |
| 11 | Lock bolt | 5 | 29 | Air inlet plug | 2 | 47 | Pressure regulator | 1 |
| 12 | Cross pin | 5 | 30 | Thin nut | 1 | 48 | Internal thread male connector | 2 |
| 13 | Snap retainer | 10 | 31 | Inlet paint joint | 1 | 49 | Pressure gauge | 1 |
| 14 | Tank assemblage | 1 | 32 | Union nut | 1 | 50 | Gas valve | 3 |
| 15 | Bolt | 2 | 33 | Pressure tapping | 1 | 51 | Relief valve components | 1 |
| 16 | Blade | 2 | 34 | Gas valve | 1 | 52 | Release valve | 1 |
| 17 | Rocker stand | 1 | 35 | Air inlet seat | 1 | | | |
| 18 | | 1 | 36 | Pipe joint | 1 | | | |

Note: If you need spare parts of this model, pls feel free to contact us or the distributor where you bought this tool. Tks!